

200BZ430 -61

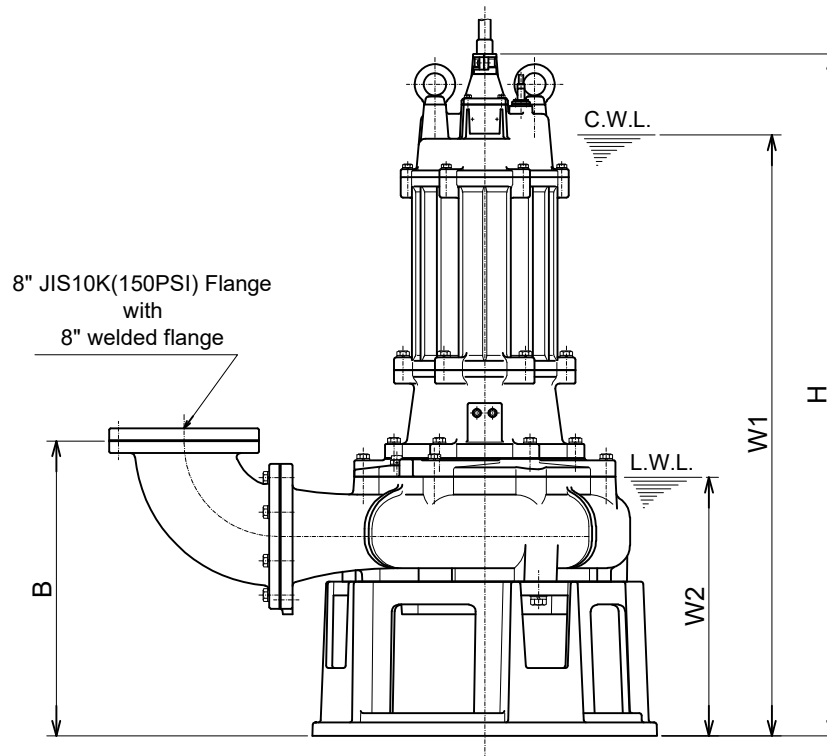
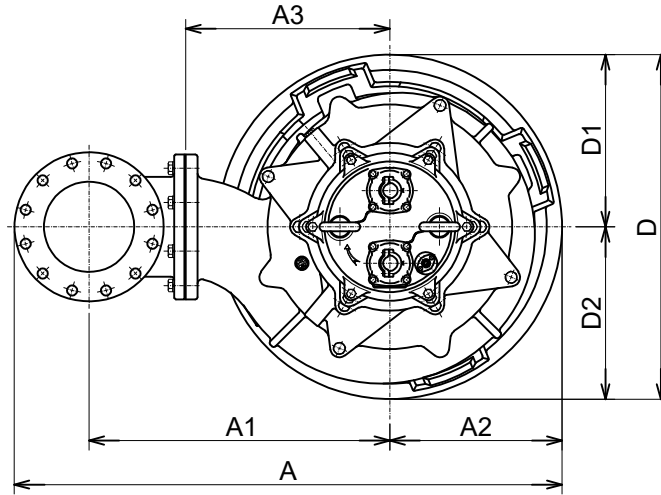

C.W.L. :Continuous running Water Level
L.W.L. :Lowest running Water Level

DIMENSIONS:USCS (Inch)

| Model | HP | NOM. SIZE | Pump & Motor | | | | | | | | | C.W.L. | L.W.L. | *Wt. (lbs.) |
|-------------|----|-----------|--------------|--------|----------|----------|---------|----------|----------|----------|---------|--------|--------|-------------|
| | | | A | A1 | A2 | A3 | B | D | D1 | D2 | H | | | |
| 200BZ430-61 | 40 | 8" | 47 9/16 | 26 1/8 | 14 15/16 | 17 11/16 | 25 9/16 | 29 15/16 | 14 15/16 | 14 15/16 | 59 3/16 | 52 1/8 | 22 1/2 | 1720 |

DIMENSIONS:METRIC (mm)

*Excluding Cable

| Model | kW | NOM. SIZE | Pump & Motor | | | | | | | | | C.W.L. | L.W.L. | *Wt. (kg) |
|-------------|----|-----------|--------------|-----|-----|-----|-----|-----|-----|-----|------|--------|--------|-----------|
| | | | A | A1 | A2 | A3 | B | D | D1 | D2 | H | | | |
| 200BZ430-61 | 30 | 200 | 1208 | 663 | 380 | 450 | 650 | 760 | 380 | 380 | 1504 | 1325 | 570 | 780 |