

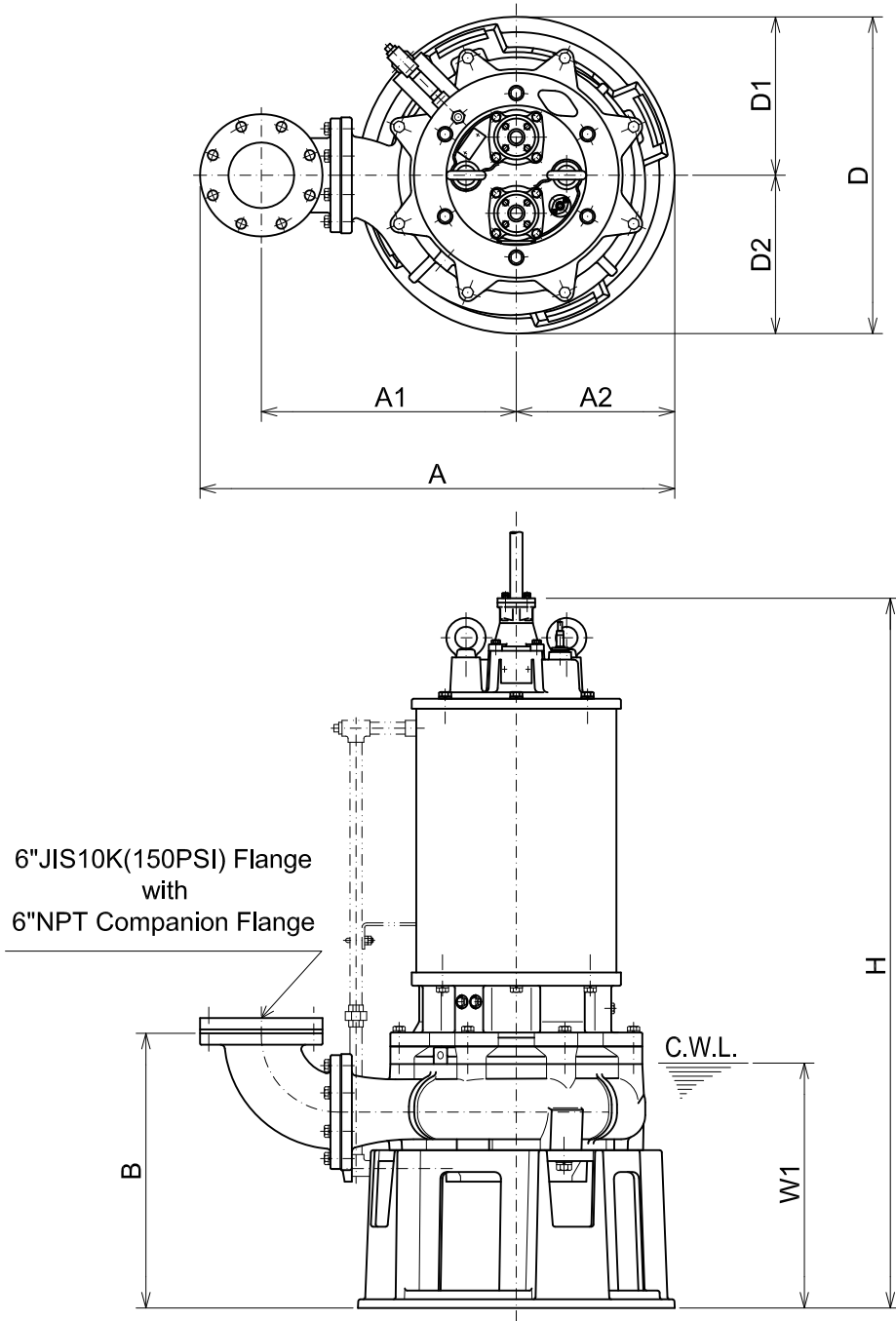

B-SERIES
SEWAGE & WASTEWATER PUMPS

DIMENSIONS

150BK437 -63



C.W.L. :Continuous running Water Level

DIMENSIONS:USCS(Inch)

Model	HP	NOM. SIZE	Pump & Motor								C.W.L.	*Wt.
			A	A1	A2	B	D	D1	D2	H	W1	(lbs.)
150BK437 -63	50	6"	42 11/16	22 15/16	14 1/4	24 3/4	28 1/2	14 1/4	14 1/4	63 11/16	22	1810

*Excluding Cable

DIMENSIONS:METRIC(mm)

Model	kW	NOM. SIZE	Pump & Motor								C.W.L.	*Wt.
			A	A1	A2	B	D	D1	D2	H	W1	(kg)
150BK437 -63	37	150	1085	583	362	628	724	362	362	1617	560	820