

**100C222-CR -61**

Bend model:  
BEND100x100 ANSI

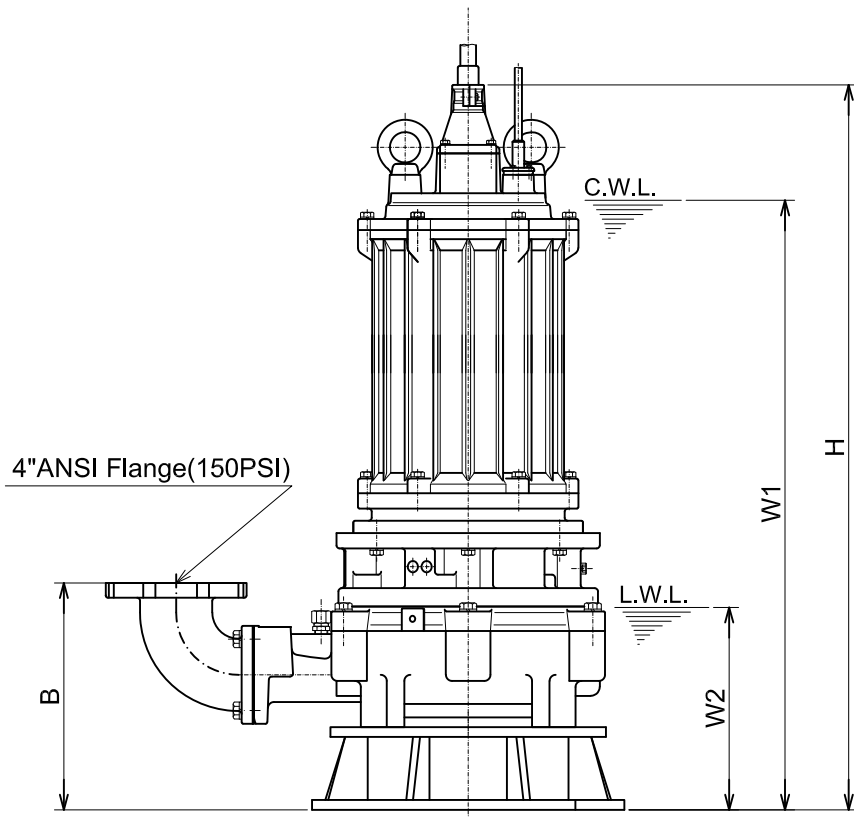
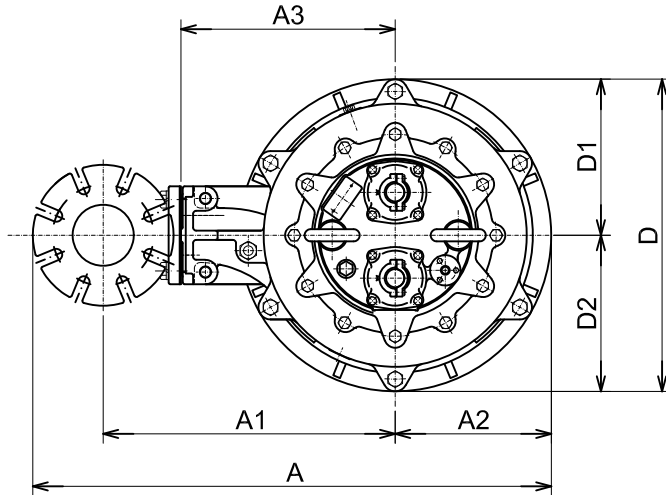

C.W.L. :Continuous running Water Level  
L.W.L.:Lowest running Water Level

**DIMENSIONS:USCS (Inch)**

Model	HP	NOM. SIZE	Pump & Motor									C.W.L. W1	L.W.L. W2	*Wt. (lbs.)
			A	A1	A2	A3	B	D	D1	D2	H			
100C222-CR-61	30	4"	33 3/4	19 3/16	10 1/16	13 3/4	14 9/16	20 1/16	10 1/16	10 1/16	46 5/8	39 1/8	13	915

**DIMENSIONS:METRIC (mm)**

\*Excluding Cable

Model	kW	NOM. SIZE	Pump & Motor									C.W.L. W1	L.W.L. W2	*Wt. (kg)
			A	A1	A2	A3	B	D	D1	D2	H			
100C222-CR-61	22	100	857	487	255	350	370	510	255	255	1184	995	330	415