

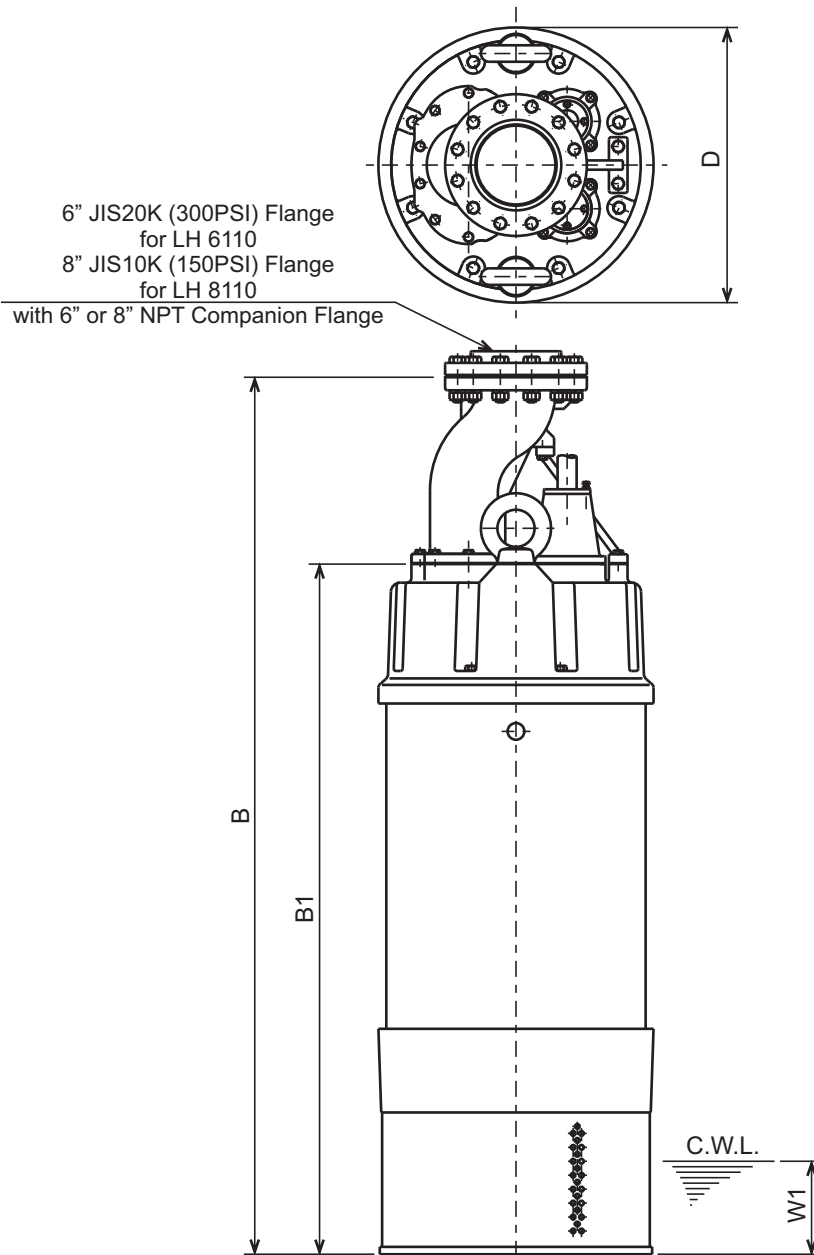

LH - SERIES (SCS 14)
STAINLESS STEEL CASTING DEWATERING PUMPS

DIMENSIONS



LH6110-14-69
LH8110-14-69

DIMENSIONS:USCS (Inch)

C.W.L. : Continuous running Water Level

Model	HP	NOM. SIZE	Pump & Motor			C.W.L. W1	*Wt. (lbs.)
			B	B1	D		
LH6110-14-69	150	6"	74 5/16	58 7/16	23 5/16	7 7/8	2970
LH8110-14-69	150	8"	74 5/16	58 7/16	23 5/16	7 7/8	2970

*Excluding Cables

DIMENSIONS:METRIC (mm)

Model	kW	NOM. SIZE	Pump & Motor			C.W.L. W1	*Wt. (kg)
			B	B1	D		
LH6110-14-69	110	150	1887	1485	592	200	1350
LH8110-14-69	110	200	1887	1485	592	200	1350