

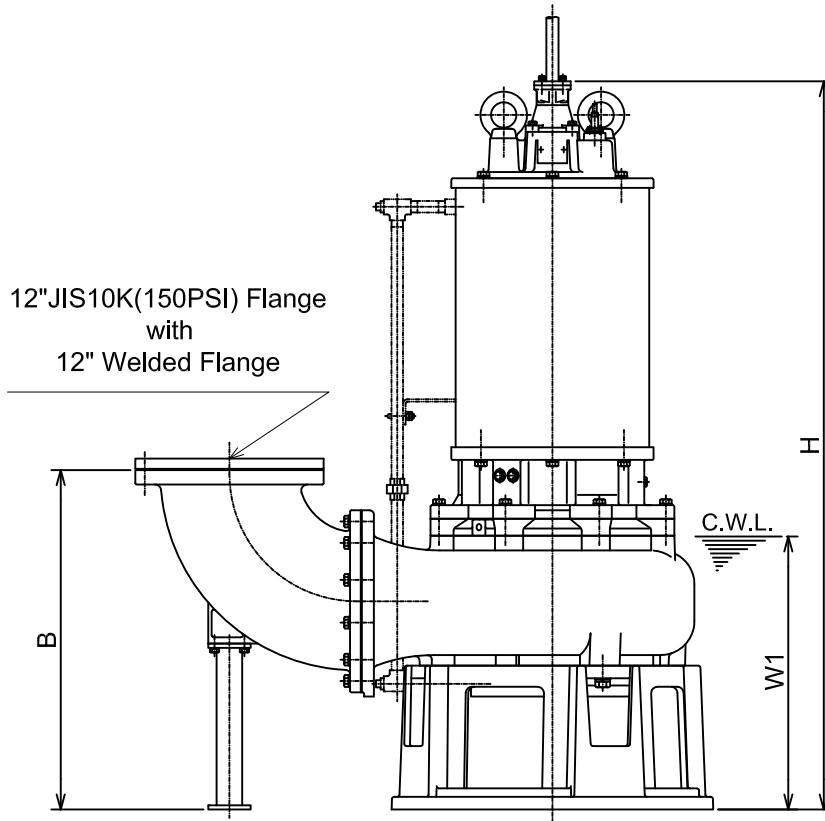

B-SERIES
SEWAGE & WASTEWATER PUMPS

DIMENSIONS

300BK630 -63

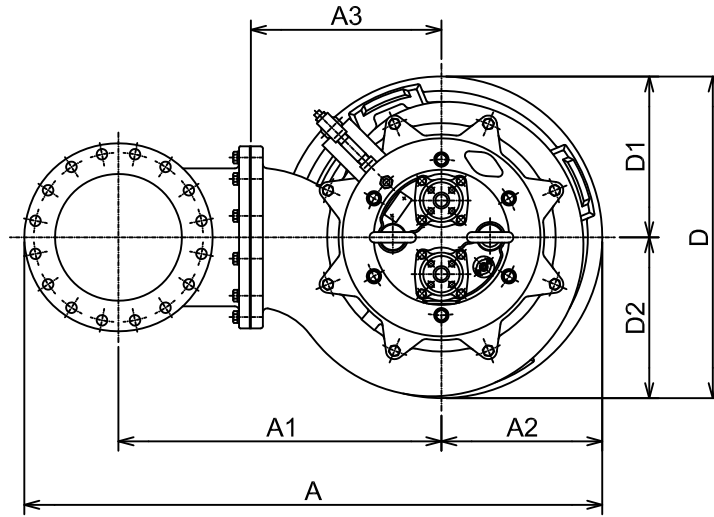

C.W.L. :Continuous running Water Level

DIMENSIONS:USCS(Inch)

Model	HP	NOM. SIZE	Pump & Motor								C.W.L.	*Wt.	
			A	A1	A2	A3	B	D	D1	D2	H	W1	(lbs.)
300BK630 -63	50	12"	53 3/4	30 1/16	14 15/16	19 11/16	31 9/16	29 15/16	14 15/16	14 15/16	67 3/16	25 1/4	2090

DIMENSIONS:METRIC(mm)

Model	kW	NOM. SIZE	Pump & Motor								C.W.L.	*Wt.	
			A	A1	A2	A3	B	D	D1	D2	H	W1	(kg)
300BK630 -63	37	300	1366	763	380	500	802	760	380	380	1706	645	950

*Excluding Cable