

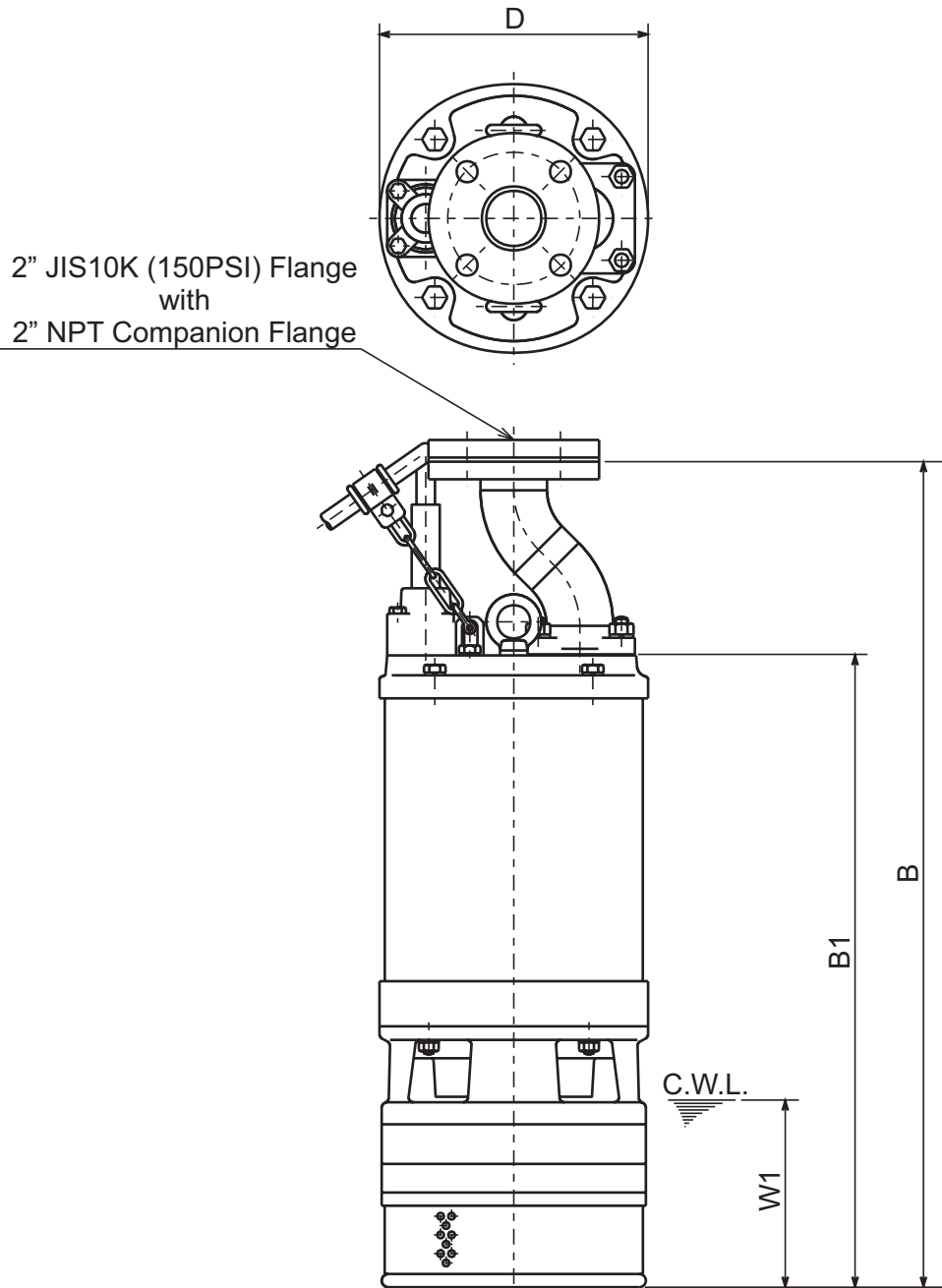

**LH-W SERIES**  
HIGH HEAD - DEWATERING PUMPS

**DIMENSIONS**

**LH25.5W-60**



C.W.L. : Continuous running Water Level

**DIMENSIONS:USCS (Inch)**

Model	HP	NOM. SIZE	Pump & Motor			C.W.L.	Wt. (lbs.)
			B	B1	D	W1	
LH25.5W-60	7.5	2"	29 1/2	22 5/8	9 5/8	6 3/4	176

**DIMENSIONS:METRIC (mm)**

Model	HP	NOM. SIZE	Pump & Motor			C.W.L.	Wt. (kg)
			B	B1	D	W1	
LH25.5W-60	5.5	50	750	574	244	170	80