

200BK422H -63

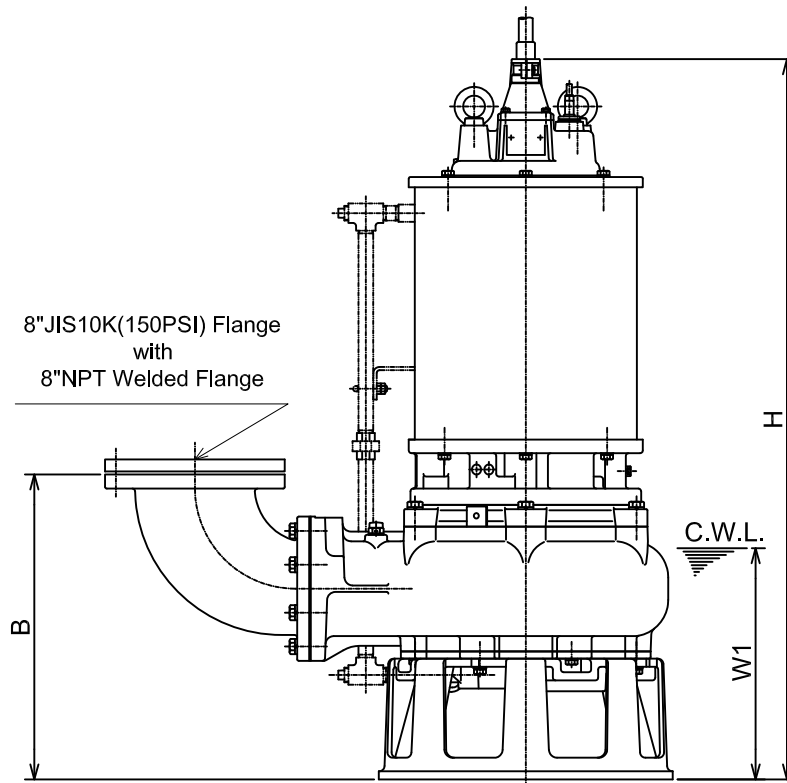
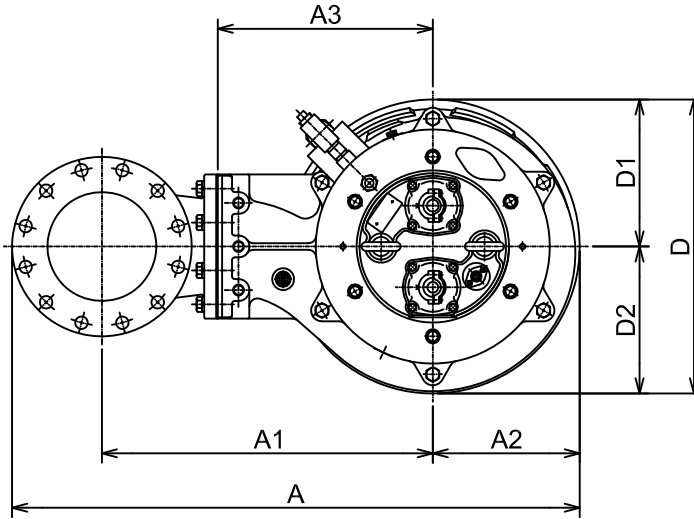

C.W.L. :Continuous running Water Level

DIMENSIONS:USCS(Inch)

Model	HP	NOM. SIZE	Pump & Motor								C.W.L. W1	*Wt. (lbs.)	
			A	A1	A2	A3	B	D	D1	D2			H
200BK422H -63	30	8"	41 1/16	23 15/16	10 5/8	15 9/16	22 1/16	21 1/4	10 5/8	10 5/8	52 1/8	16 3/4	1190

DIMENSIONS:METRIC(mm)

Model	kW	NOM. SIZE	Pump & Motor								C.W.L. W1	*Wt. (kg)	
			A	A1	A2	A3	B	D	D1	D2			H
200BK422H -63	22	200	1043	608	270	395	561	540	270	270	1324	425	540

*Excluding Cable