

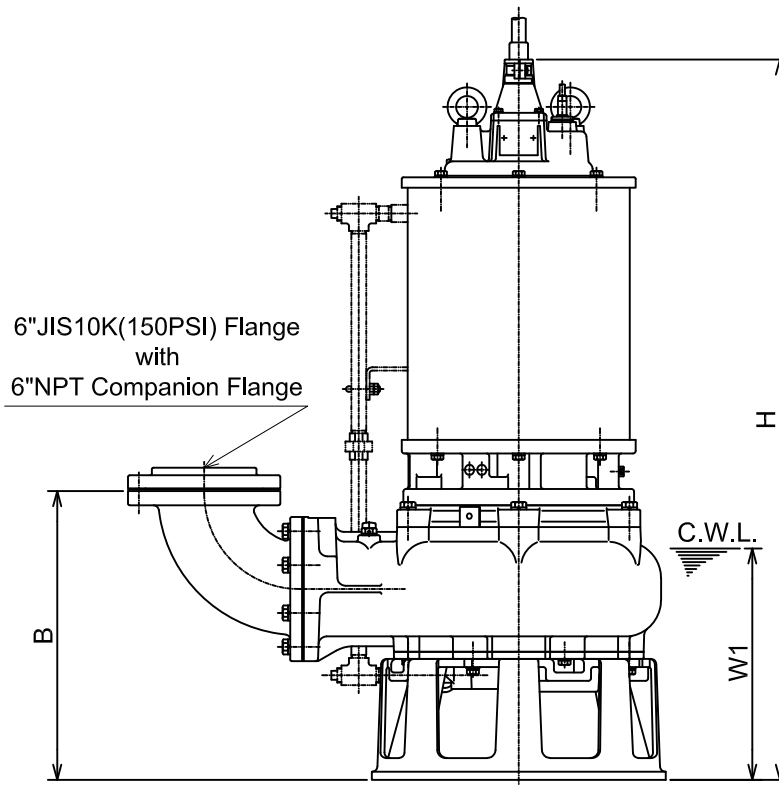

B-SERIES
SEWAGE & WASTEWATER PUMPS

DIMENSIONS

150BK422 -64

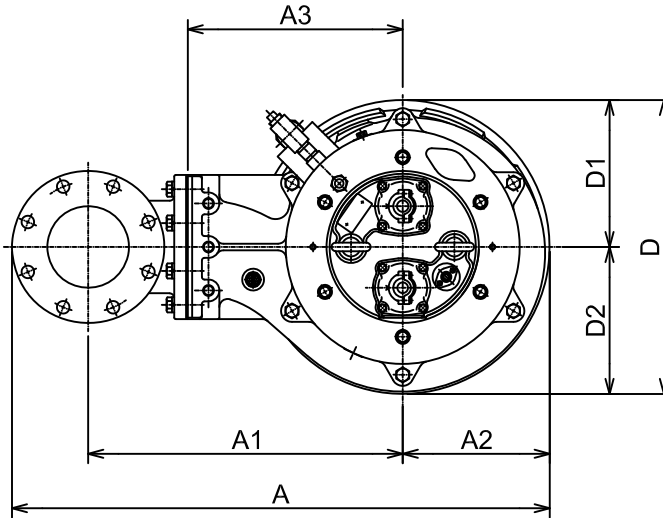

C.W.L. :Continuous running Water Level

DIMENSIONS:USCS(Inch)

Model	HP	NOM. SIZE	Pump & Motor								C.W.L. W1	*Wt. (lbs.)	
			A	A1	A2	A3	B	D	D1	D2			H
150BK422 -63	30	6"	38 7/8	22 3/4	10 5/8	15 9/16	22 1/16	21 1/4	10 5/8	10 5/8	52 1/8	16 3/4	1180

DIMENSIONS:METRIC(mm)

Model	kW	NOM. SIZE	Pump & Motor								C.W.L. W1	*Wt. (kg)	
			A	A1	A2	A3	B	D	D1	D2			H
150BK422 -63	22	150	988	578	270	395	531	540	270	270	1324	425	535

*Excluding Cable