

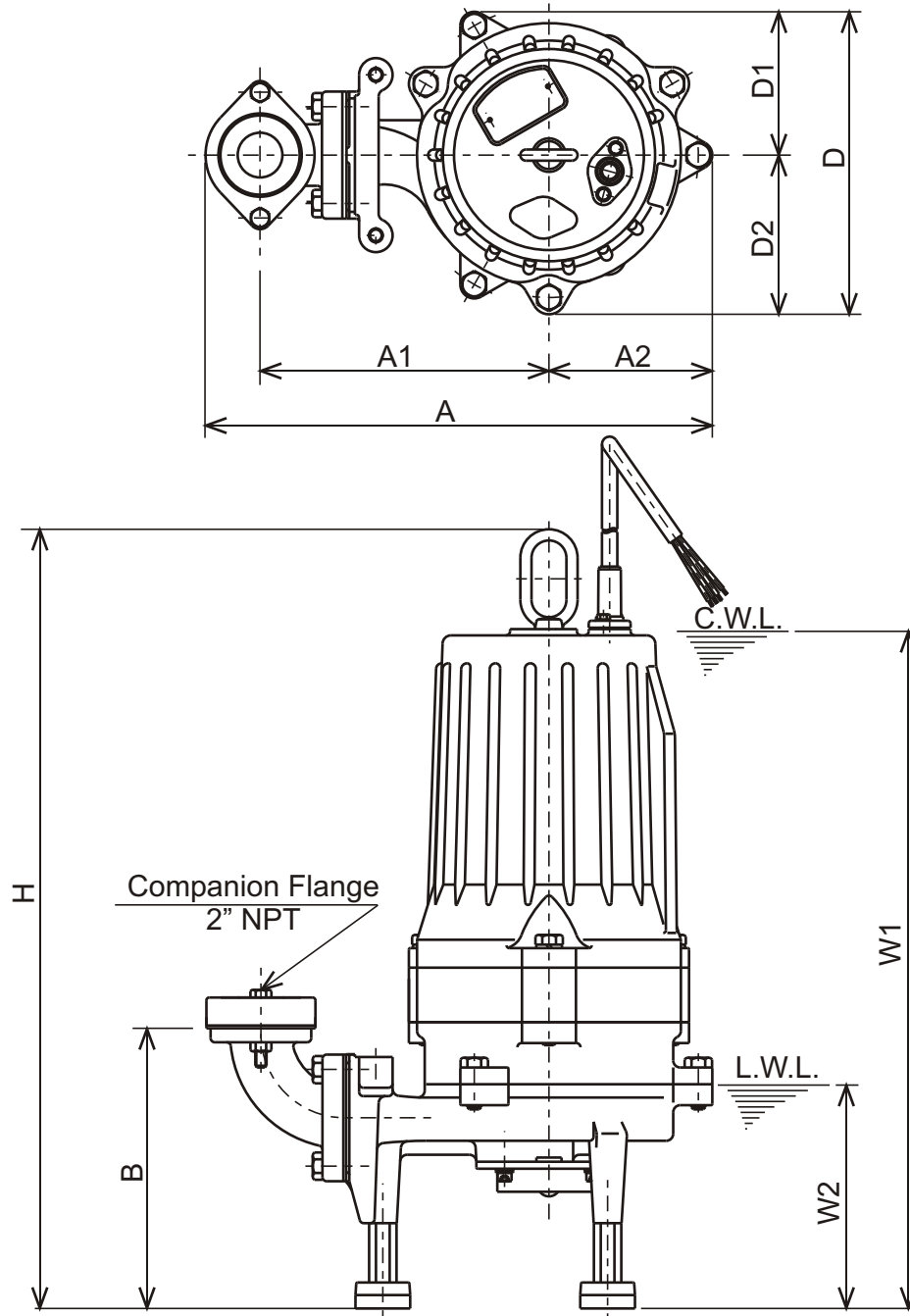

**MG - SERIES
GRINDER PUMPS**

DIMENSIONS

50MG21.5-62



C.W.L. : Continuous running Water Level
L.W.L. : Lowest running Water Level

DIMENSIONS:USCS (Inch)

Model	HP	NOM. SIZE	Pump & Motor								C.W.L. W1	L.W.L. W2	Wt. (lbs.)
			A	A1	A2	B	D	D1	D2	H			
50MG21.5-62	2	2"	14 5/16	8 1/8	4 5/8	7 15/16	8 9/16	4 1/16	4 1/2	21 15/16	19 1/8	6 1/4	79

DIMENSIONS:METRIC (mm)

Model	kW	NOM. SIZE	Pump & Motor								C.W.L. W1	L.W.L. W2	Wt. (kg)
			A	A1	A2	B	D	D1	D2	H			
50MG21.5-62	1.5	50	363	207	117	201	217	103	114	558	485	160	36