

TOS50B2.75 -63

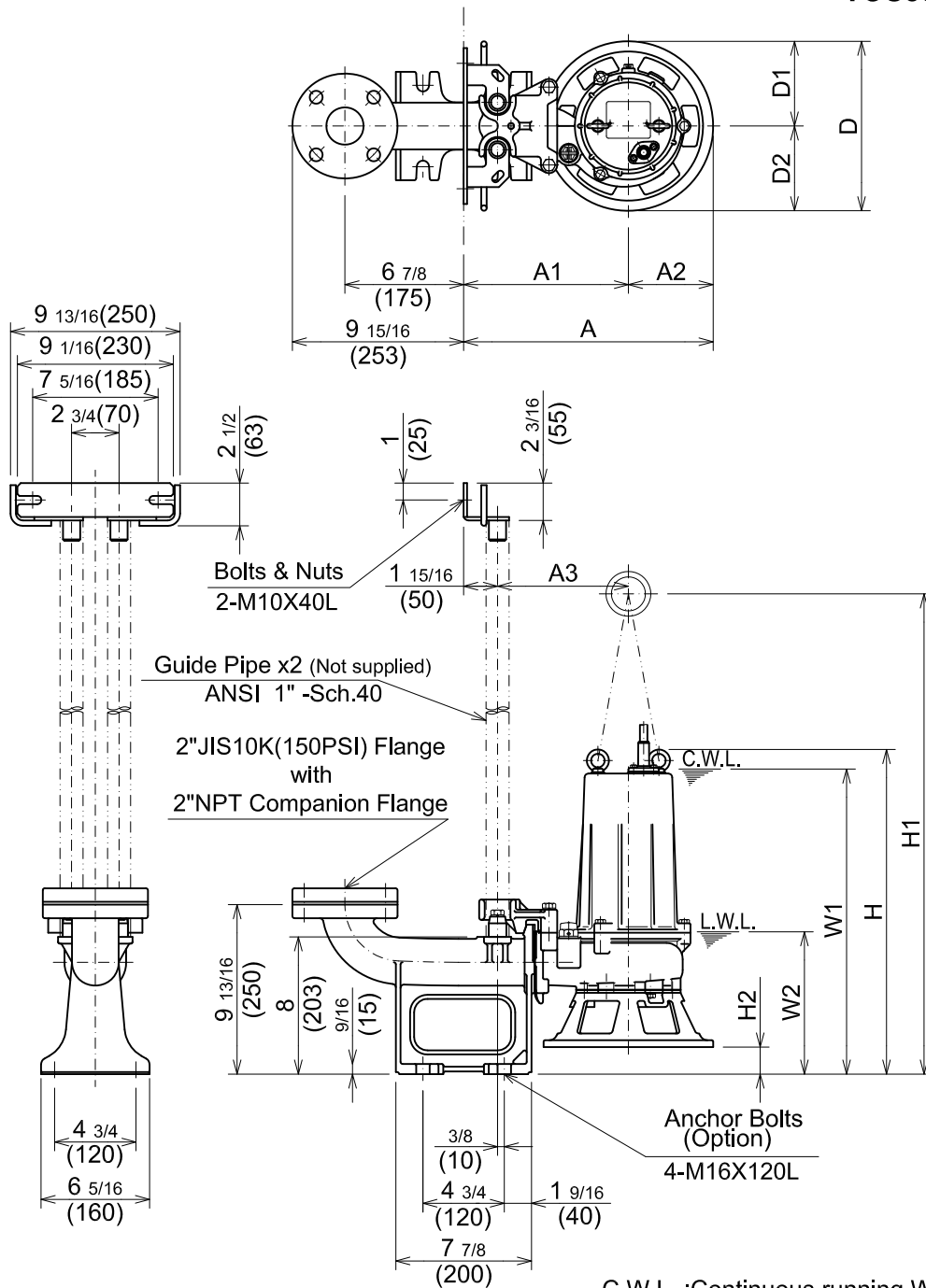

C.W.L. :Continuous running Water Level
L.W.L. :Lowest running Water Level

DIMENSIONS:USCS(Inch)

Model	HP	NOM. SIZE	Pump & Motor										C.W.L.	L.W.L.	Wt. (lbs.)
			A	A1	A2	A3	D	D1	D2	H	H1	H2			
TOS50B2.75 -63	1	2"	14 1/2	9 9/16	4 15/16	7 5/8	9 13/16	4 15/16	4 15/16	18 7/8	27 7/8	1 9/16	17 3/4	8 1/4	53

DIMENSIONS:METRIC(mm)

Model	kW	NOM. SIZE	Pump & Motor										C.W.L.	L.W.L.	Wt. (kg)
			A	A1	A2	A3	D	D1	D2	H	H1	H2			
TOS50B2.75 -63	0.75	50	368	243	125	193	250	125	125	479	708	40	450	210	24