

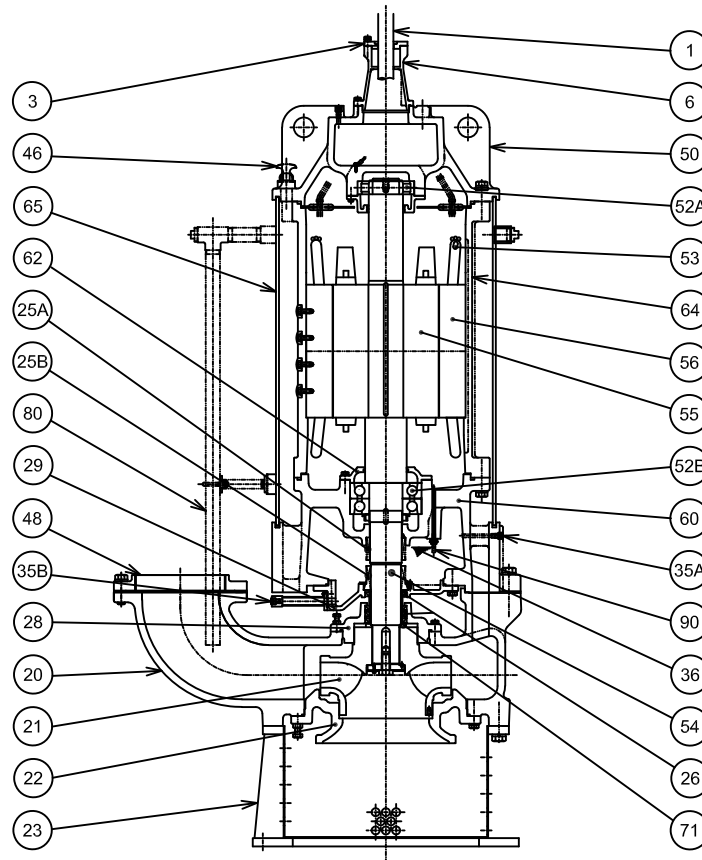

GSZ-150-4



ITEM#	DESCRIPTION	MAIN MATERIAL / NOTE	ASTM, AISI CODE	RELATED EN CODE	Q'TY
1	Power Cable	Chloroprene Sheath AWG 1/0-3C, 4-1C, 14-3C-50ft			1
	Power Cable	Chloroprene Sheath AWG 1/0-3C-50ft			1
3	Gland	Cast Iron	A48M Class30B	EN 1561 GJL-200	2
6	Stuffing Box	Cast Iron	A48M Class30B	EN 1561 GJL-200	2
20	Pump Casing	Cast Iron	A48M Class30B	EN 1561 GJL-200	1
21	Impeller	High Chrome Cast Iron	A532 ClassIII TypeA	DIN 1695 G-X260Cr27	1
22	Suction Cover	Cast Iron	A48M Class30B	EN 1561 GJL-200	1
23	Suction Strainer	Steel	A283 Grade D	EN 10025 S275	1
25A	Mechanical Seal	Carbide Alloy / MU0095			1
25B	Mechanical Seal	Silicon Carbide / ML0090			1
26	Oil Seal	NBR / TC10012513			4
28	Seal Housing	Cast Iron	A48M Class30B	EN 1561 GJL-200	1
29	Oil Casing	Cast Iron	A48M Class30B	EN 1561 GJL-200	1
35A	Oil Plug	Stainless Steel	S 30400	1.4301	4
35B	Oil Plug	Stainless Steel	S 30400	1.4301	1
36	Lubricant	Turbine Oil ISO VG32 or SAE 10W-20			
46	Air Release Valve	Steel (Cold Rolled)	A109/A1008	EN 10130	1
48	Companion Flange	Cast Iron / NPT 10" JIS10K	A48M Class30B	EN 1561 GJL-200	1
50	Motor Bracket	Cast Iron	A48M Class30B	EN 1561 GJL-200	1
52A	Upper Bearing	#NU316			1
52B	Lower Bearing	#7320BTDB			1
53	Motor Protector				3
54	Shaft	Stainless Steel	S 42000	1.4021	1
55	Rotor				1
56	Stator				1
60	Bearing Housing	Cast Iron	A48M Class30B	EN 1561 GJL-200	1
62	Bearing Cover	Cast Iron	A48M Class30B	EN 1561 GJL-200	1
64	Motor Housing	Cast Iron	A48M Class30B	EN 1561 GJL-200	1
65	Outer Cover	Steel Pipe (& Steel)	A53 Type F (& A283 Grade D)	DIN 1615 St 33 (EN 10025 S275)	1
71	Shaft Sleeve	Stainless Steel	S 40300	1.4000	1
80	Cooling Pipe Set	Steel	A283 Grade D	EN 10025 S275	1
90	Leak Sensor (Electrode)	Stainless Steel	S 30300	1.4305	1