

PARTS LIST		HI-VOLUME DEWATERING PUMP			12/3/2013	
ITEM	PART No.	DESCRIPTION	QTY	SIZE	MATERIAL	NOTES
1	001-313-31	Cabtyre Cable Set (50') 60Hz (USA)	1	2PNCTF4Cx5.5mm2	KR-2	
2	006-126-14	Stuffing Box	1	No.2	FC	
3	140-055-10	Hex.Bolt	4	M8x25	SUS304	
4	070-107-18	Cable Clamp	1		FC	
5	140-035-14	Hex.Bolt	2	M6x20	SUS304	
6	008-139-16	Mould Cover 60Hz(USA)	1	KR2-4	CR	
7	010-120-18	Cable Clip	1	No.2-1	SPC	
8	010-122-10	Cable Clip Rubber	1	No.2	NBR	
9	141-004-33	Hex.Nut	1	M6	S35C	
10	140-101-12	Hex.Bolt	4	M12x50	SUS304	
11	095-131-18	Chain	1	4mm(3L)	SS	
12	011-110-11	Shackle	1	6mm(M8,SC)	SS	
13	140-032-37	Hex.Bolt	1	M6x15	SWRM	
14	142-165-10	Spring Washer	4	M12	SUS304	
15	070-103-10	L-Shape Fitting	1	KT-55	SPC	
16	009-129-16	Terminal	6	E (Small)	CU	
17	009-101-12	Terminal(C/W Screw)	3	d12x(d6.6xd6.6)x25l	C3604	
18	002-129-15	Heat Shrink Tube (Sold per meter)	m	EVA(d14x1t)	(V/m)	
19	002-132-11	Heat Shrink Tube (Sold per meter)	m	A4(d17x0.27t)	(V/m)	
20	140-000-01	Hex.Bolt	4	M10x30(B=14)	SUS304	
21	140-000-01	Hex.Bolt	5	M10x30(B=14)	SUS304	
22	032-162-13	Hose Coupling	1	GH-37L(NPT-4)	FC	
23	121-141-15	Packing	1	KRB-3/4	NBR	*
24	041-105-16	Flange	1	KRS-6x4	FC	
25	122-285-15	O-Ring	1	155xd3.1	NBR	*
26	140-100-11	Hex.Bolt	1	M12x45	SUS304	
27	142-165-10	Spring Washer	1	M12	SUS304	
28	068-159-18	Handle	1	KRS-C6/A6/8S(T)	SGP+SPC	
29	143-013-15	Pan Screw	1	M4x6	SWRM	
30	142-160-31	Spring Washer	1	M4	SWRH	
31	009-147-10	Terminal	1	R-5.5-5	CU	
32	050-364-13	Motor Bracket	1		FC	
33	122-250-11	O-Ring	1	230xd3.8	NBR	*
34	053-307-17	Motor Protector 208/230V-60Hz(USA)	1	KA314-HLFQ00	(H.C)	
		Motor Protector 460V-60Hz(USA)	1			
		Motor Protector 575V-60Hz(USA)	1			
35	143-126-12	Pan Screw (w/Spring Washer/Plain Washer)	2	M4x12	SWRM	
36	142-198-12	Wave Washer	1	6306	SK5	
37	052-109-14	Bearing	1	6306ZZC3		
38	058-120-19	Lead Wire Protection Plate	1	d94xd220x1.6t	Bakelite	
39	055-563-19	Rotor	1Set			
40	147-021-18	Impeller Key	1	8x8x44l	SUS420	
41	056-491-18	Stator 208/230V-60Hz(USA)	1Set			
		Stator 460V-60Hz(USA)	1Set			

* Indicates items included in set

PARTS LIST		HI-VOLUME DEWATERING PUMP			12/3/2013	
ITEM	PART No.	DESCRIPTION	QTY	SIZE	MATERIAL	NOTES
		Stator 575V-60Hz(USA)	1Set			
42	121-304-18	Packing (Water Way, Upp.)	1	KRS-7.5/11(T)	NBR	*
43	064-451-11	Motor Frame	1		FC	
44	140-100-11	Hex.Bolt	4	M12x45	SUS304	
45	121-247-12	Packing	1	d12.3xd18x2t	PE	*
46	035-113-18	Oil Plug	1	M12x14	SUS304	
47	121-129-17	Packing (Water Way, Low.)	1	KRS-7.5/11	NBR	*
48	122-311-11	O-Ring	1	220xd3.5	NBR	*
49	140-029-28	Hex.Bolt	3	M6x10	SWRM	
50	062-102-18	Bearing Fixing Plate	1	d85xd125x3.2t	SS	
51	052-112-10	Bearing	1	6309ZZC3		
52	146-027-11	Retaining Ring	1	C45	SK5	
53	122-140-17	O-Ring	1	G-145(144.4xd3.1)	NBR	*
54	060-221-18	Bearing Housing	1		FC	
55	140-054-48	Hex.Bolt	4	M8x20	SWRM	
56	025-195-13	Mechanical Seal	1	H-35	SiC	
57	143-070-23	Pan Screw	2	M5x6	SWRM	
58	030-156-18	Oil Lifter	1	H-35(A)(T)	Resin	
59	143-070-10	Pan Screw	3	M5x6	SWRM	
60	030-150-12	Seal Stopper	1	H-35(A)(T)	SPCC	
61	020-380-12	Pump Casing	1	KRS-B6	FC	
62	142-165-10	Spring Washer	1	M12	SUS304	
63	140-113-17	Hex.Bolt	1	M12x120	SUS304	
64	026-123-13	Oil Seal	1	TC-406211	NBR	
65	071-128-47	Shaft Sleeve	1	KRS-7.5/11KW	SUS403	
66	040-110-24	Impeller Shim		d32.5xd58x0.3t	SUS304	
67	021-573-17	Impeller (60Hz)	1	KRS2-100	HiCrFC	
68	024-126-23	Connection Rod	1	KRS-100	FCMB	
69	024-120-14	Stirrer	1	GPN-80	HiCrFC	
70	142-130-16	Plain Washer	1	M16	SUS304	
71	141-008-40	Hex.Nut	1	M16(H=10)	SUS304	
72	140-139-19	Hex.Bolt	1	M16x143(B=19)	SUS304	
73	120-112-14	Packing (S.Cover)		d260xd314x0.5t	PE	
74	033-110-19	Suction Plate	1	KRS-100	HiCrFC	
75	140-057-41	Hex.Bolt	3	M8x35(B=14)	SWRM	
76	022-420-24	Suction Cover	1	KRS-100	FC	
77	142-129-25	Plain Washer	3	M12	SPC	
78	140-097-14	Hex.Bolt	3	M12x30	SUS304	
79	142-163-18	Spring Washer	3	M8	SUS304	
80	141-005-18	Hex.Nut	3	M8	SUS304	
81	142-129-25	Plain Washer	3	M12	SPC	
82	144-478-15	Stud Bolt	3	M12x111(21/25)	SUS403	
83	023-241-19	Strainer Stand	1Set	KRS-100	SPC+SGP	
84	142-165-10	Spring Washer	3	M12	SUS304	

* Indicates items included in set

PARTS LIST		HI-VOLUME DEWATERING PUMP				12/3/2013
ITEM	PART No.	DESCRIPTION	QTY	SIZE	MATERIAL	NOTES
85	141-007-10	Hex.Nut	3	M12	SUS304	
		Packing O-Ring Set				
	173-439-14	Packing O-Ring Set	1Set	(Marked by *)		
23	121-141-15	Packing (Hose Coupling)	1	KRB-3/4	NBR	*
25	122-285-15	O-Ring (Flange)	1	155xd3.1	NBR	*
33	122-250-11	O-Ring (M.Bracket/M.Frame)	1	230xd3.8	NBR	*
42	121-304-18	Packing (Water Way, Upp.)	1	KRS-7.5/11(T)	NBR	*
48	122-311-11	O-Ring (M.Frame/P.Casing)	1	220xd3.5	NBR	*
45	121-247-12	Packing (Oil Plug)	1	d12.3xd18x2t	PE	*
47	121-129-17	Packing (Water Way, Low.)	1	KRS-7.5/11	NBR	*
53	122-140-17	O-Ring (M.Frame/Brq.Housing)	1	G-145(144.4xd3.1)	NBR	*
		Lubricant		Turbine Oil VG32 2,300ml		

PARTS LIST		HI-VOLUME DEWATERING PUMP			12/3/2013	
ITEM	PART No.	DESCRIPTION	QTY	SIZE	MATERIAL	NOTES

EXPLODED VIEW

KRS2-100

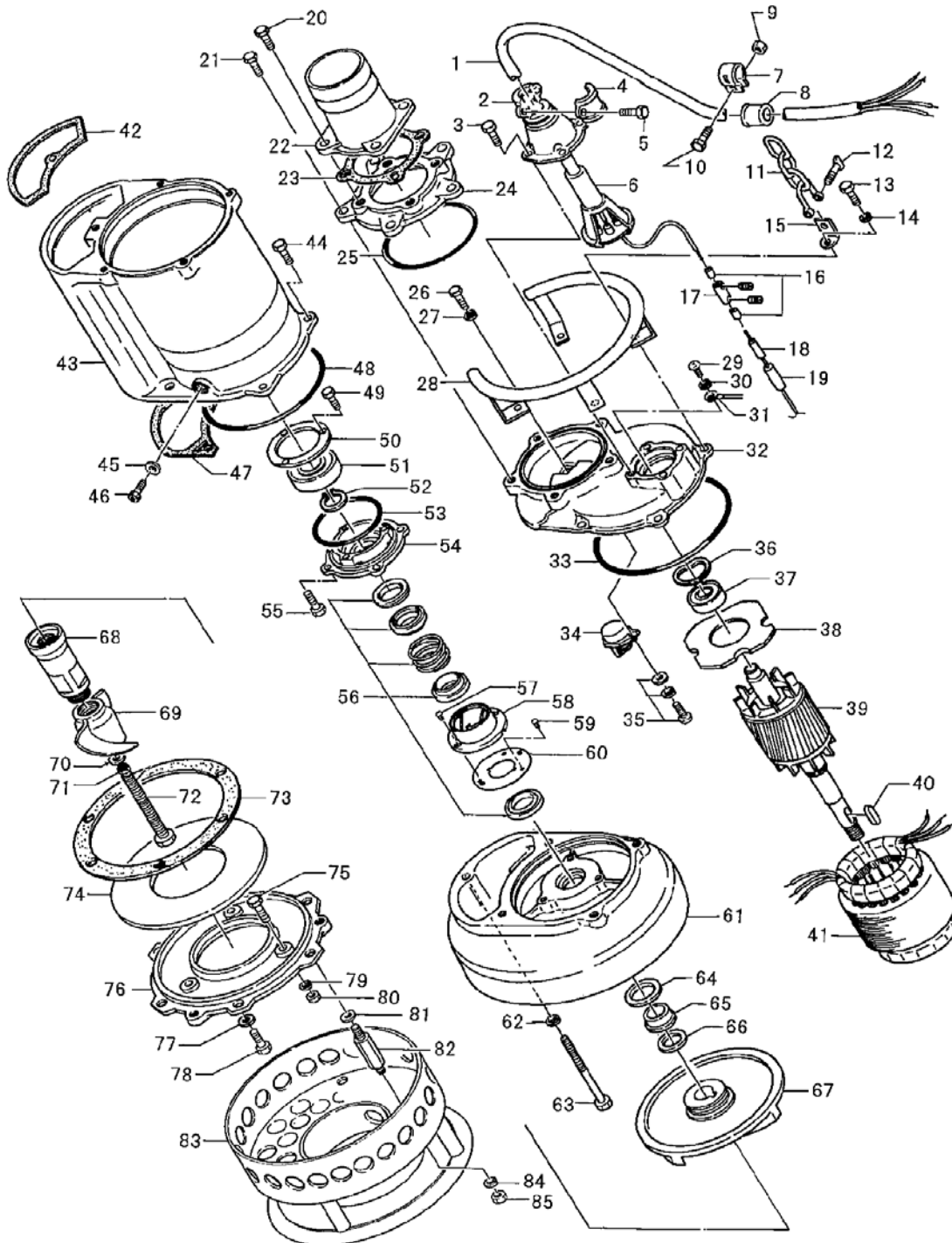

(C-00007-1)