

PARTS LIST		CONTRACTOR PUMP			2/19/2013	
ITEM	PART No.	DESCRIPTION	QTY	SIZE	MATERIAL	NOTES
1	140-427-17	Hex.Bolt (w/Plain Washer)	2	M5x15	SUS304	
2	003-190-10	Gland	1		SUS316	
3	001-803-20	Cabtyre Cable Set (10m)440V-60Hz(USA)	1	VCT4Cx1.25mm2	LBT	
4	140-056-11	Hex.Bolt	2	M8x30	SUS304	
5	068-177-12	Handle	2	AB-4(SUS)	FC	
6	035-124-12	Air Tightness Test Plug	1	M10x15	SUS304	
7	121-246-11	Packing	1	d10.3xd16x2t	PE	
8	051-186-12	Motor Head Cover	1		FC	
9	009-000-07	Intermediate Lead Wire	1Set	#17072-2,L=200		
10	143-085-21	Pan Screw (w/Spring Washer)	1	M4x6	SWRM	
11	053-271-11	Motor Protector 220V-60Hz(USA)	1	KA313-GCXL103	(T)	
12	143-126-38	Pan Screw (w/Spring Washer/Plain Washer)	2	M4x12	SWRM	
13	122-285-15	O-Ring	1	155xd3.1	NBR	
14	064-369-11	Motor Frame	1		FC	
15	142-163-18	Spring Washer	4	M8	SUS304	
16	140-055-10	Hex.Bolt	4	M8x25	SUS304	
17	142-195-19	Wave Washer		6204/6303(d47x.0.3t)	SK5	
18	052-106-11	Bearing	1	6303ZZC3		
19	058-116-12	Lead Wire Protection Plate	1	d60xd150x1t	Bakelite	
20	056-002-95	Stator 220V-60Hz(USA)	1Set			
21	055-446-15	Rotor	1Set	w/Bearing		
22	147-091-19	Impeller Key	1	5x5x25L	SUS403	
23	052-108-13	Bearing	1	6305ZZC3		
24	025-252-19	Mechanical Seal	1	H-20A	SiC+CCBN	
25	143-070-23	Pan Screw	2	M5x6	SWRM	
26	030-144-13	Oil Lifter	1	H-20(A)(T)	Resin	
27	143-070-10	Pan Screw	3	M5x6	SWRM	
28	030-153-15	Seal Stopper	1	H-20(A)	SPCC	
29	122-285-15	O-Ring	1	155xd3.1	NBR	
30	029-210-20	Oil Casing (Oil Lifter)	1	AB-15T	FC	
31	144-161-12	Stud Bolt	3	M8x115(20/30)	SUS304	
32	121-246-11	Packing	1	d10.3xd16x2t	PE	
33	035-124-12	Oil Plug	1	M10x15	SUS304	
34	040-104-25	Impeller Shim		d18.2xd29x0.3t	SUS304	
35	021-997-11	Impeller (60Hz)	1	150AB41.5-61	FC	
36	142-165-10	Spring Washer	1	M12	SUS304	
37	141-007-10	Hex.Nut	1	M12	SUS304	
38	047-111-13	Impeller Thread Protection Cap	1	No.13	NBR	
39	121-195-14	Packing	1	d260xd265.6x3t	NBR	
40	065-182-11	Outer Cover	1	AB-15T	SUS304	
41	121-195-14	Packing	1	d260xd265.6x3t	NBR	
42	020-621-18	Pump Casing	1	AB-15T	FC	
43	142-163-18	Spring Washer	3	M8	SUS304	
44	141-005-18	Hex.Nut	3	M8	SUS304	



MODEL 150AB41.5-60

PARTS LIST		CONTRACTOR PUMP				2/19/2013
ITEM	PART No.	DESCRIPTION	QTY	SIZE	MATERIAL	NOTES
45	023-330-16	Strainer Stand	1	AB-15T	SUS304	
46	142-126-19	Plain Washer	3	M6	SUS304	
47	143-042-26	Pan Screw	3	M6x10	SUS304	
		<For NPT>				
	032-000-51	Hose Coupling	1	NPT-6(AB41.5)	FC	
		<Oil Ring Version>				
30	029-210-17	Oil Casing (Oil Ring)	1	AB-15T	FC	
AA	030-118-21	Oil Ring	1	H-20	SPC	
BB	143-070-10	Pan Screw	3	M5x6	SWRM	
		<Packing O-Ring Set>				
	173-354-14	Packing O-Ring Set	1Set	(Marked by *)		
7	121-246-11	Packing (Air Tightness Test Plug)	1	d10.3xd16x2t	PE	
13	122-285-15	O-Ring (Motor Head Cover/M.Frame)	1	155xd3.1	NBR	
29	122-285-15	O-Ring (M.Frame/O.Casing)	1	155xd3.1	NBR	
32	121-246-11	Packing (Oil Plug)	1	d10.3xd16x2t	PE	
39	121-195-14	Packing (Pump Head Cover/Out.Cover)	1	d260xd265.6x3t	NBR	
41	121-195-14	Packing (Out.Cover/P.Casing)	1	d260xd265.6x3t	NBR	
		Lubricant		Turbine Oil VG32 600ml		

* Indicates items included in set

PARTS LIST		CONTRACTOR PUMP				2/19/2013
ITEM	PART No.	DESCRIPTION	QTY	SIZE	MATERIAL	NOTES

EXPLODED VIEW

150AB41.5-51/61 (150AB41.5-50/60)

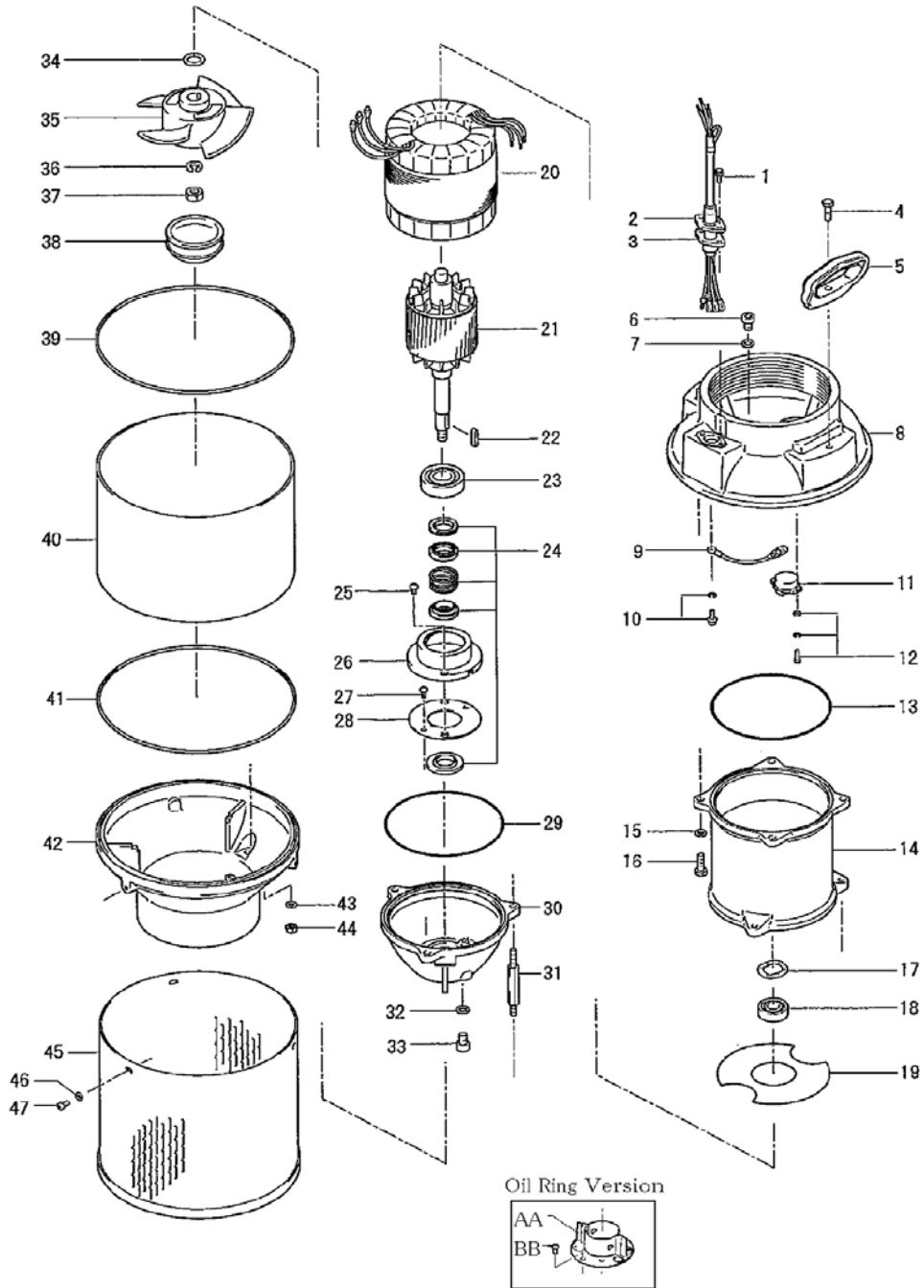

C-00221-1