

GSZ5-37-4H

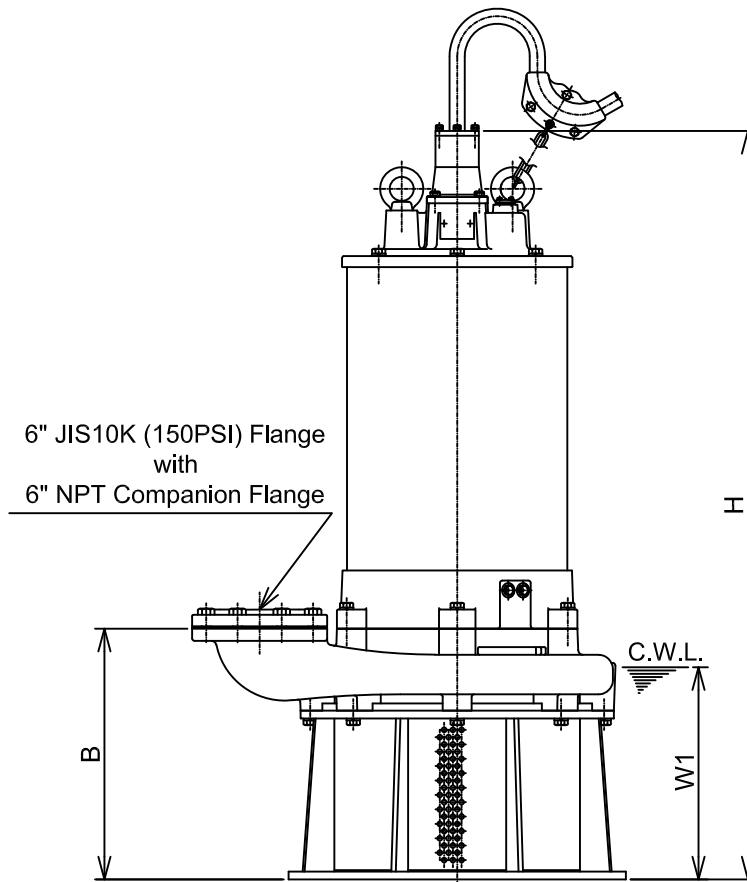
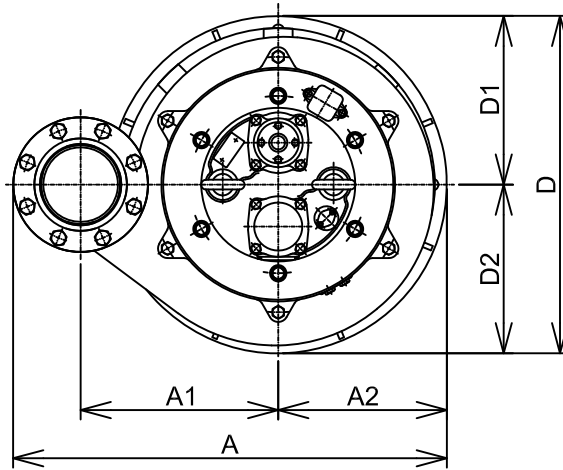

C.W.L. : Continuous running Water Level

DIMENSIONS:USCS (Inch)

Model	HP	NOM. SIZE	Pump & Motor								C.W.L.	*Wt.
			A	A1	A2	B	D	D1	D2	H	W1	(lbs.)
GSZ5-37-4H	50	6"	35 7/16	16 1/8	13 3/4	20 1/2	27 9/16	13 3/4	13 3/4	61 1/8	17 5/16	1310

DIMENSIONS:METRIC (mm)

Model	kW	NOM. SIZE	Pump & Motor								C.W.L.	*Wt.
			A	A1	A2	B	D	D1	D2	H	W1	(kg)
GSZ5-37-4H	37	150	900	410	350	520	700	350	350	1553	440	595

*Excluding Cable