

GSZ5-22-6

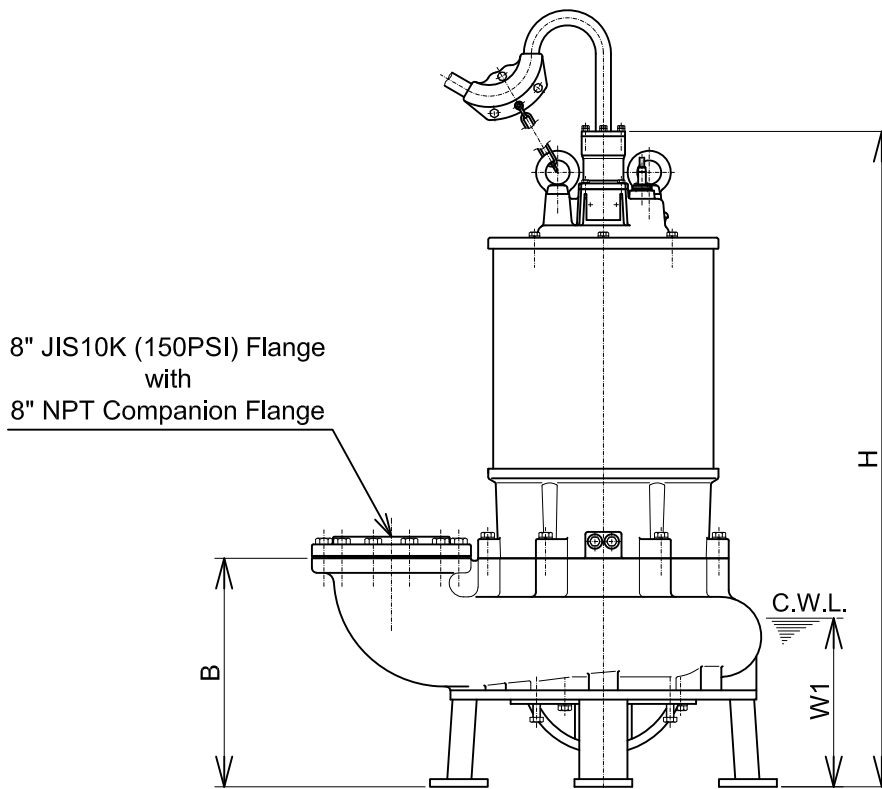
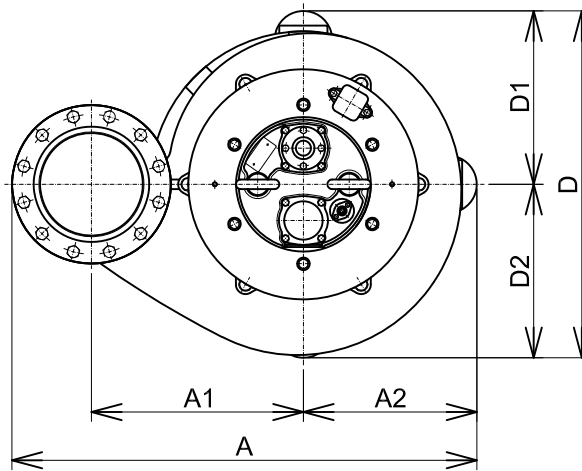

C.W.L. : Continuous running Water Level

DIMENSIONS:USCS (Inch)

Model	HP	NOM. SIZE	Pump & Motor								C.W.L.	*Wt.
			A	A1	A2	B	D	D1	D2	H	W1	(lbs.)
GSZ5-22-6	30	8"	38	17 5/16	14 3/16	18 11/16	28 3/8	14 3/16	14 3/16	53 9/16	13 3/4	1510

DIMENSIONS:METRIC (mm)

Model	kW	NOM. SIZE	Pump & Motor								C.W.L.	*Wt.
			A	A1	A2	B	D	D1	D2	H	W1	(kg)
GSZ5-22-6	22	200	965	440	360	474	720	360	360	1360	350	685

*Excluding Cable