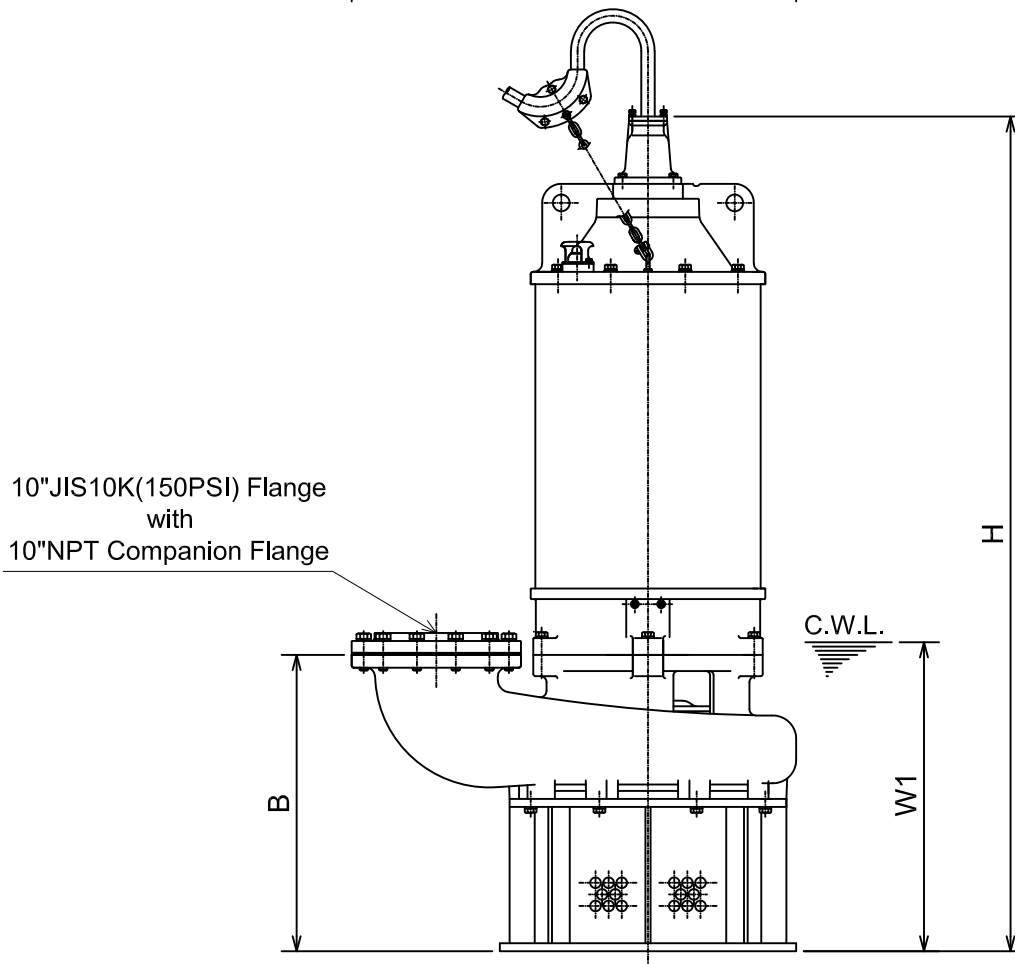
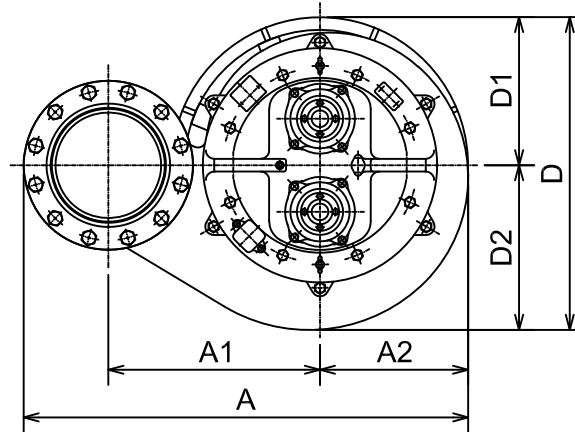

**GSZ2-75-4L**

C.W.L. :Continuous running Water Level

**DIMENSIONS:USCS (Inch)**

Model	HP	NOM. SIZE	Pump & Motor								C.W.L.	*Wt.
			A	A1	A2	B	D	D1	D2	H	W1	(lbs.)
GSZ2-75L-4	100	10"	41 5/16	19 11/16	13 3/4	27 9/16	29 1/8	13 3/4	15 5/16	77 5/8	28 3/4	2640

**DIMENSIONS:METRIC (mm)**

Model	kW	NOM. SIZE	Pump & Motor								C.W.L.	*Wt.
			A	A1	A2	B	D	D1	D2	H	W1	(kg)
GSZ2-75L-4	75	250	1050	500	350	700	739	350	389	1972	730	1200

\*Excluding Cable