

**GSZ2-55-4**  
**GSZ2-75-4**

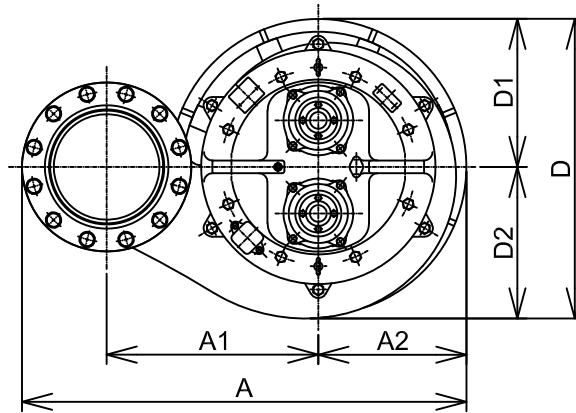

10" JIS10K (150PSI) Flange  
with  
10" NPT Companion Flange

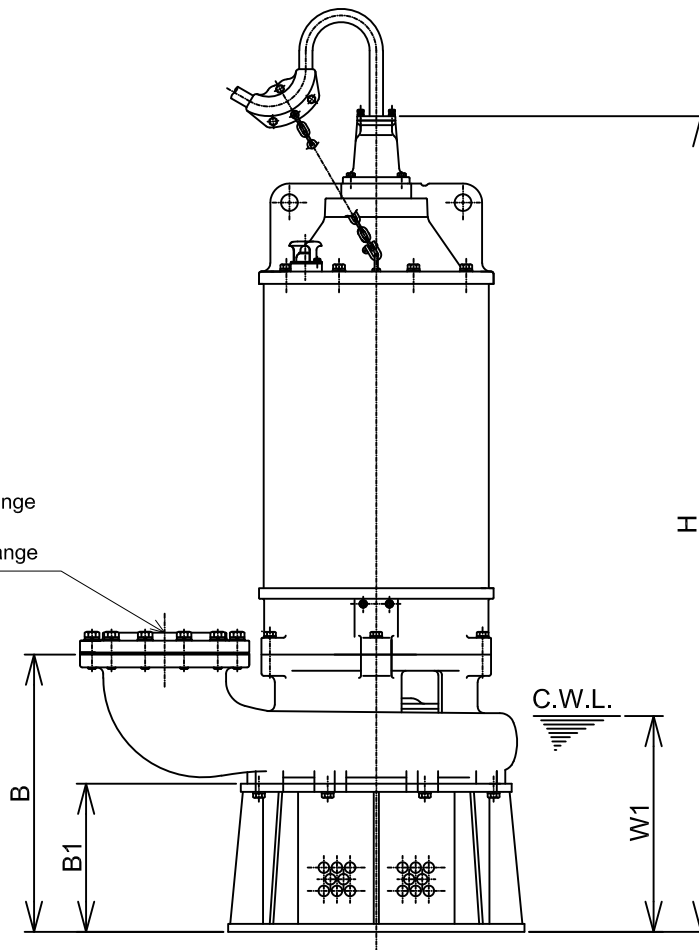

C.W.L. :Continuous running Water Level

**DIMENSIONS:USCS (Inch)**

Model	HP	NOM. SIZE	Pump & Motor									C.W.L. W1	*Wt. (lbs.)
			A	A1	A2	B	B1	D	D1	D2	H		
GSZ2-55-4	75	10"	41 5/16	19 11/16	13 3/4	25 13/16	13 3/4	27 7/8	13 3/4	14 1/8	75 7/8	20 1/8	2430
GSZ2-75-4	100	10"	41 5/16	19 11/16	13 3/4	25 13/16	13 3/4	27 7/8	13 3/4	14 1/8	75 7/8	20 1/8	2680

**DIMENSIONS:METRIC (mm)**

Model	kW	NOM. SIZE	Pump & Motor									C.W.L. W1	*Wt. (kg)
			A	A1	A2	B	B1	D	D1	D2	H		
GSZ2-55-4	55	250	1050	500	350	655	350	708	350	358	1927	510	1105
GSZ2-75-4	75	250	1050	500	350	655	350	708	350	358	1927	510	1215

\*Excluding Cable