

GSZ-150-4

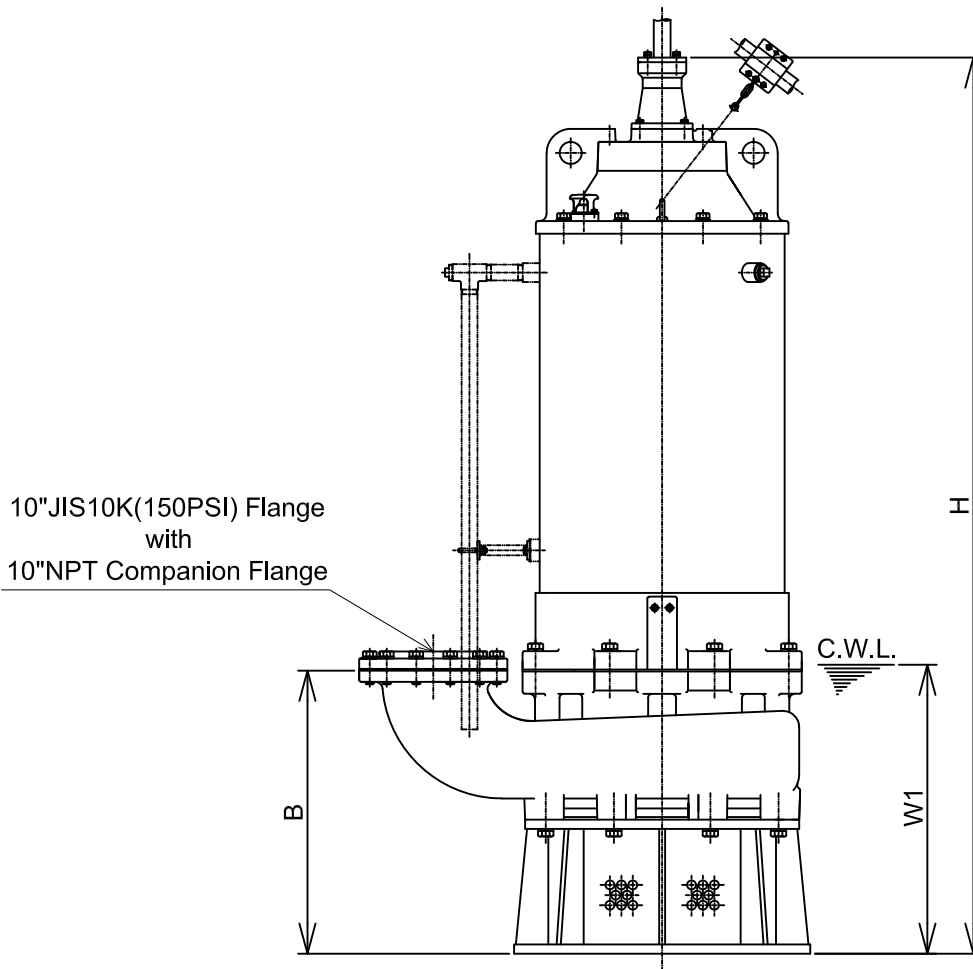
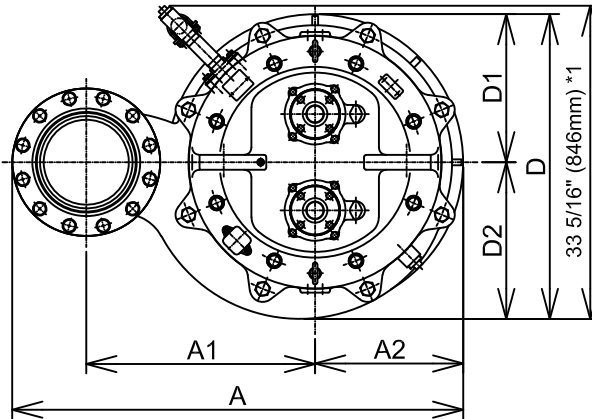

C.W.L. :Continuous running Water Level
*1 is reference

DIMENSIONS:USCS (Inch)

Model	HP	NOM. SIZE	Pump & Motor								C.W.L.	*Wt.
			A	A1	A2	B	D	D1	D2	H	W1	(lbs.)
GSZ-150-4	200	10"	47 15/16	24 5/16	15 3/4	30 1/16	32 3/8	15 3/4	16 5/8	95 1/4	30 3/4	5130

DIMENSIONS:METRIC (mm)

Model	kW	NOM. SIZE	Pump & Motor								C.W.L.	*Wt.
			A	A1	A2	B	D	D1	D2	H	W1	(kg)
GSZ-150-4	150	250	1218	618	400	764	823	400	423	2420	780	2330

*Excluding Cable