

50SQ2-2.4S-61
50SQ2-2.75-61

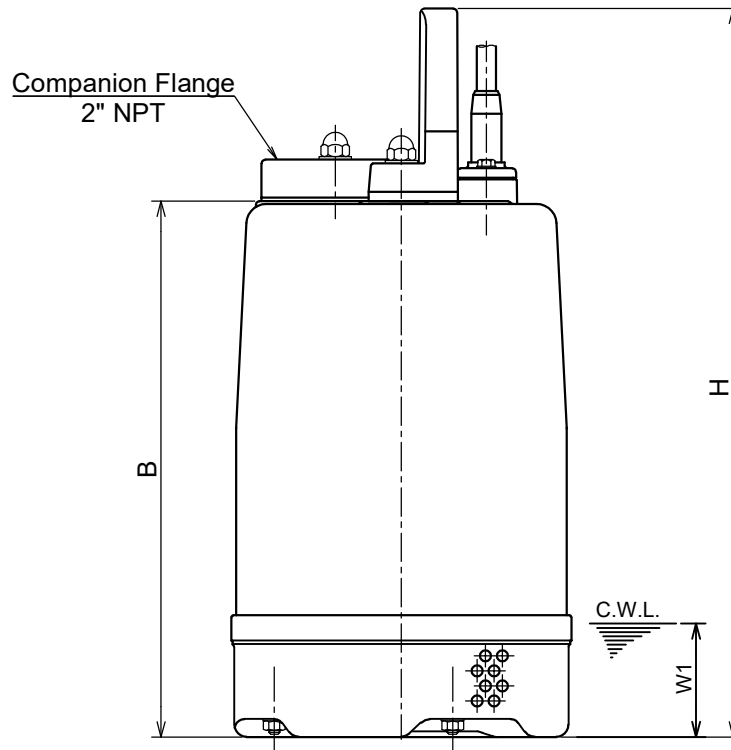
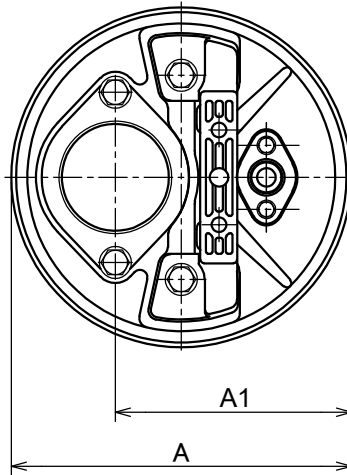

C.W.L. :Continuous running Water Level

DIMENSIONS:USCS (Inch)

Model	HP	NOM. SIZE	Pump & Motor				C.W.L. W1	*Wt. (lbs.)
			A	A1	B	H		
50SQ2-2.4S-62	1/2	2"	7 1/16	4 15/16	10 3/8	14 7/16	2 3/8	23
50SQ2-2.75-62	1	2"	7 1/16	4 15/16	11 3/16	15 3/16	2 3/8	26

DIMENSIONS:METRIC (mm)

Model	kW	NOM. SIZE	Pump & Motor				C.W.L. W1	*Wt. (kg)
			A	A1	B	H		
50SQ2-2.4S-62	0.40	50	180	125	264	366	60	10.5
50SQ2-2.75-62	0.75	50	180	125	284	386	60	12

*Excluding Cable